

Sayın Müşteri,
Satın aldığınız bu ürün size ulaşmadan önce tüm ürünlerimiz Test edilmiş, kontrol edilmiş ve paketlenmiştir. Ancak taşıma esnasında bazı parçalar zarar görebilir. Böyle bir durumda karşılıksız ürünün tamamını geri göndermeyin. Sadece hasarlı parçayı ve malzemeyi isteyin. Gerekliliği parça ve malzemelerin kodunu kurulumda bulabilirsiniz. Montaja başlamadan önce kutulardan çıkan ürünler eksiksiz olarak olduğundan emin olun. Birden fazla ürün satın alıyorsanız montajını tamamlamadığınız ikinci ürünü açarak karışıklık yaratmayınız. Kurulumu başlamadan önce her parçayı hafif nemli bir bezle silin ve kurulumu başlatın. Lütfen mobilyalarınızı amacı dışında kullanmayınız.

Dear Customer,
Before this product you have purchased reaches you, all of our has been tested and checked and packaged. However, some parts may be damaged during transportation. If you encounter such a situation, do not send the entire product back, and simply ask for the damaged part and the material.

You can find the code of the required parts and materials in the installation. Before starting the assembly, the products coming out of the boxes are complete and harmless. make sure it is.

If you have purchased more than one product, without completing the assembly of a single product.

Do not cause confusion by opening the second product. Before starting the installation, wipe each part with a slightly damp cloth and start the installation.

You can start.
Please do not use your furniture for other than its intended purpose.

| PARÇA KODU | PARÇA ADI | ADET |
|------------|---------------------|------|
| 1 | SAĞ PANO | 1 |
| 2 | SOL PANO | 1 |
| 3 | SAĞ YAN TAHTA | 1 |
| 4 | SOL YAN TAHTA | 1 |
| 5 | AYAKUCU | 1 |
| 6 | BAŞUCU ÖN PANO | 1 |
| 7 | ARA KAYIT | 1 |
| 8 | BAZA DİBİ 160 | 2 |
| 9 | BAZA SUNTASI | 2 |
| 10 | ALT DOŞEME SAĞ | 1 |
| 11 | ALT DOŞEME SOL | 1 |
| 12 | DOSEME | 6 |
| 13 | KERTIKLİ DOSEME SAĞ | 1 |
| 14 | KERTIKLİ DOSEME SOL | 1 |
| 15 | | |
| 16 | | |
| 17 | | |
| 18 | | |
| 19 | | |
| 20 | | |
| 21 | | |
| 22 | | |
| 23 | | |
| 24 | | |

BONİTA KARYOLA

KONUMLANDIRMA YAPARKEN MALZEMELERİN KODUNA VE YERİNE DİKKAT EDELİM
LET'S PAY ATTENTION TO THE CODE AND LOCATION OF THE MATERIALS WHEN POSITIONING

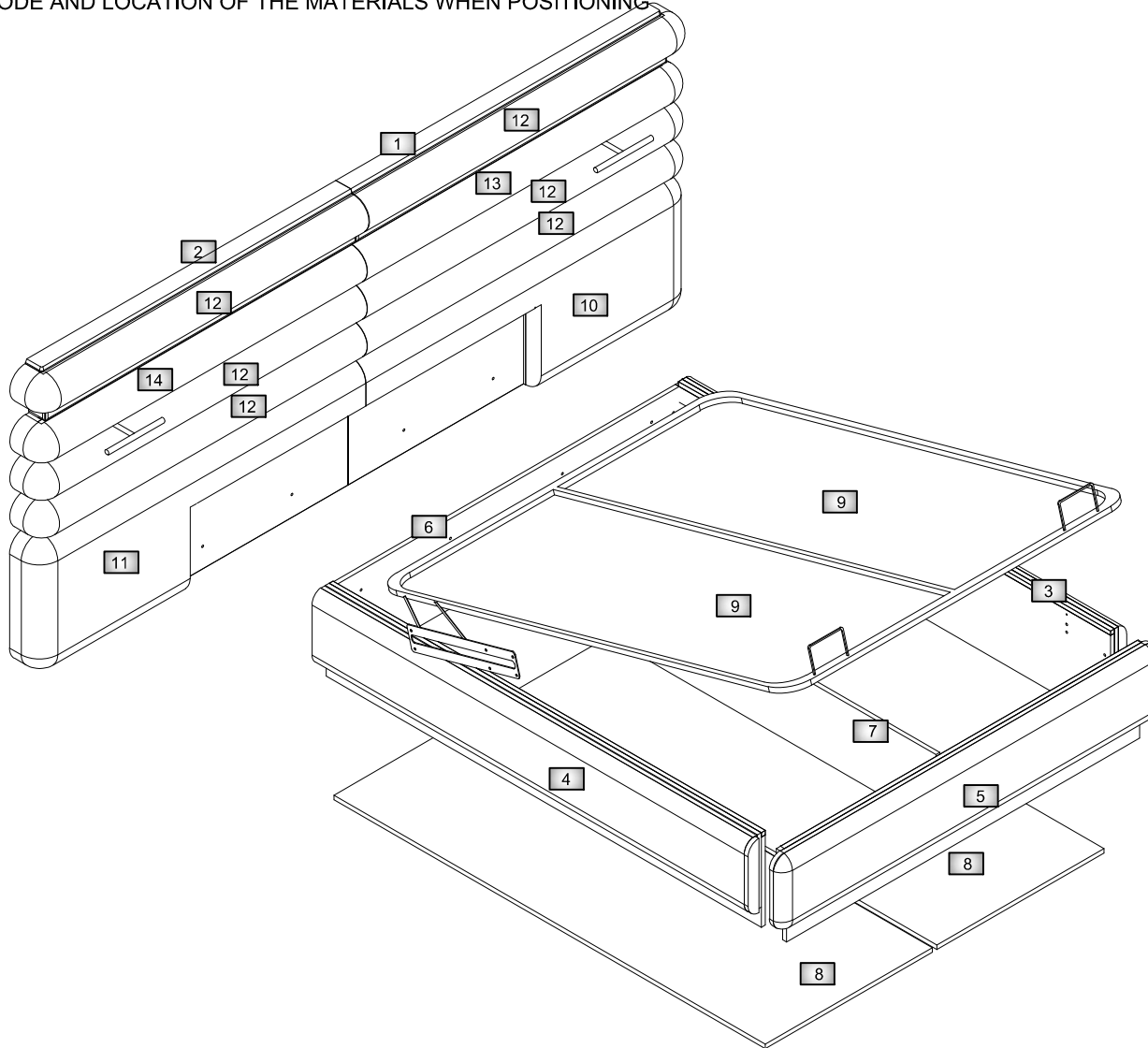

| Code | Item | Qty |
|------|---------------------|-----|
| A | Fix screw | 4 |
| B | FIX LOCK | 4 |
| C | FIX PLUG | 4 |
| E 2 | 3.5*25 SCREWS | 18 |
| KD | KOŞUĞU BAĞLANTILARI | 4 |
| V10 | M8 T10 SCREWS | 36 |
| E 3 | 4*40 SCREWS | 50 |
| KV50 | 8*50+ PUL SCREWS | 10 |
| E 1 | 3.5*20 SCREWS | 16 |
| APK | APLIK | 2 |

DETAYLI KURULAMA KODU OKUTUNUZ / READ THE DETAILED DRYING CODE
Yedek parça ihtiyacınız olması durumunda lütfen montaj talimatlarında gösterilen "Model Kodu" ve "Aksesuar Kodu"nu belirtiniz.
In case you need a sparepart, please indicate "Model Code" and "Accessory Code" shown in the assembly instructions.

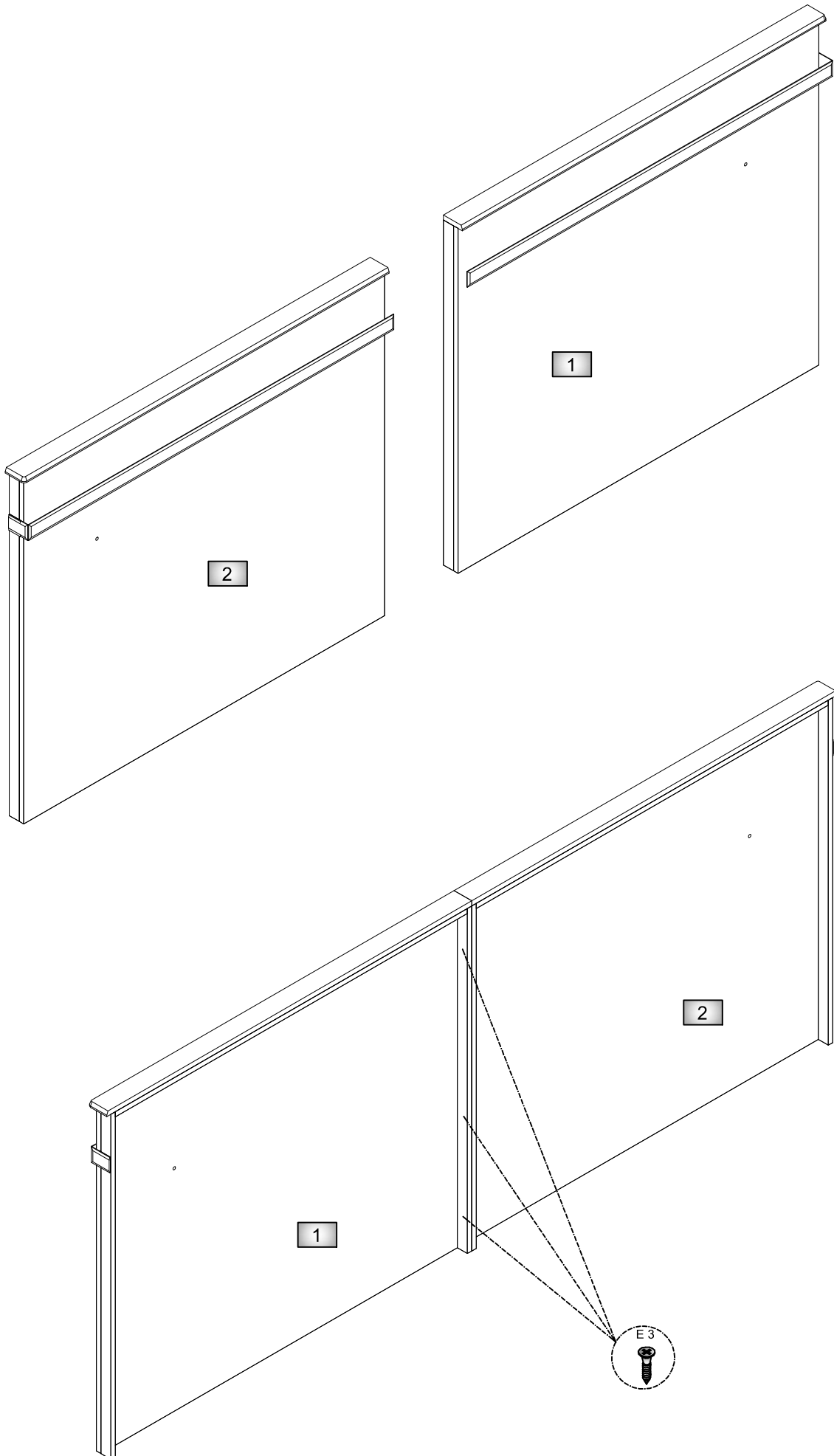

ALTTAN BASLAYARAK DOSEMELER 4*40 SUNTA VİDASI İLE SABİTLENİR

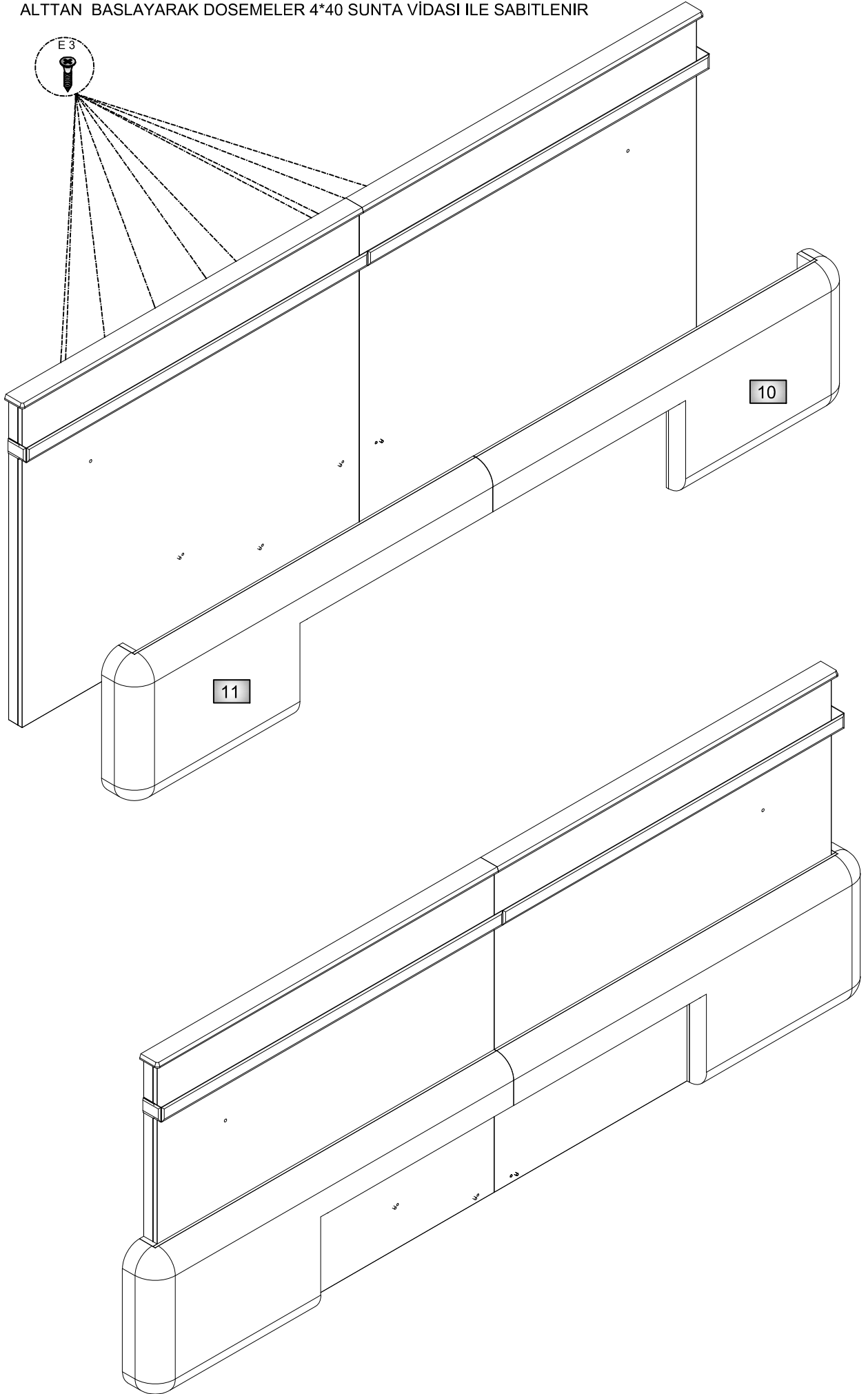

ALT DOSEMEYE BASTIRILARAK DOSEMELER PANOLARA 4*40 VIDA ILE SABITLENIR

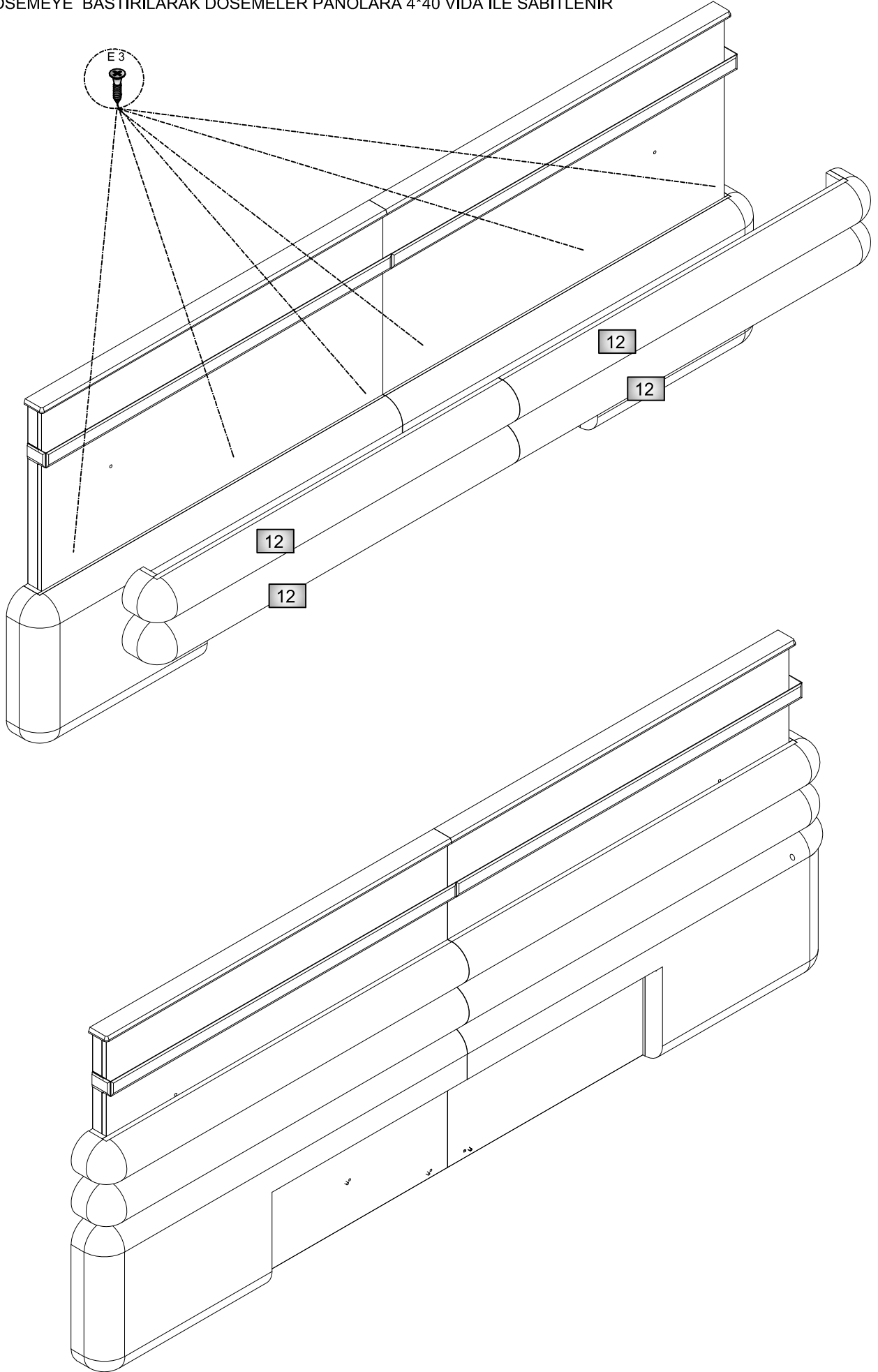

KABLOLAR DELIKTEN GECIRIP APLIKLERI IŞIK ASAGIYA BAKACAK SEKILDE SOMUNLARI ILE SABITLEYINIIZ.

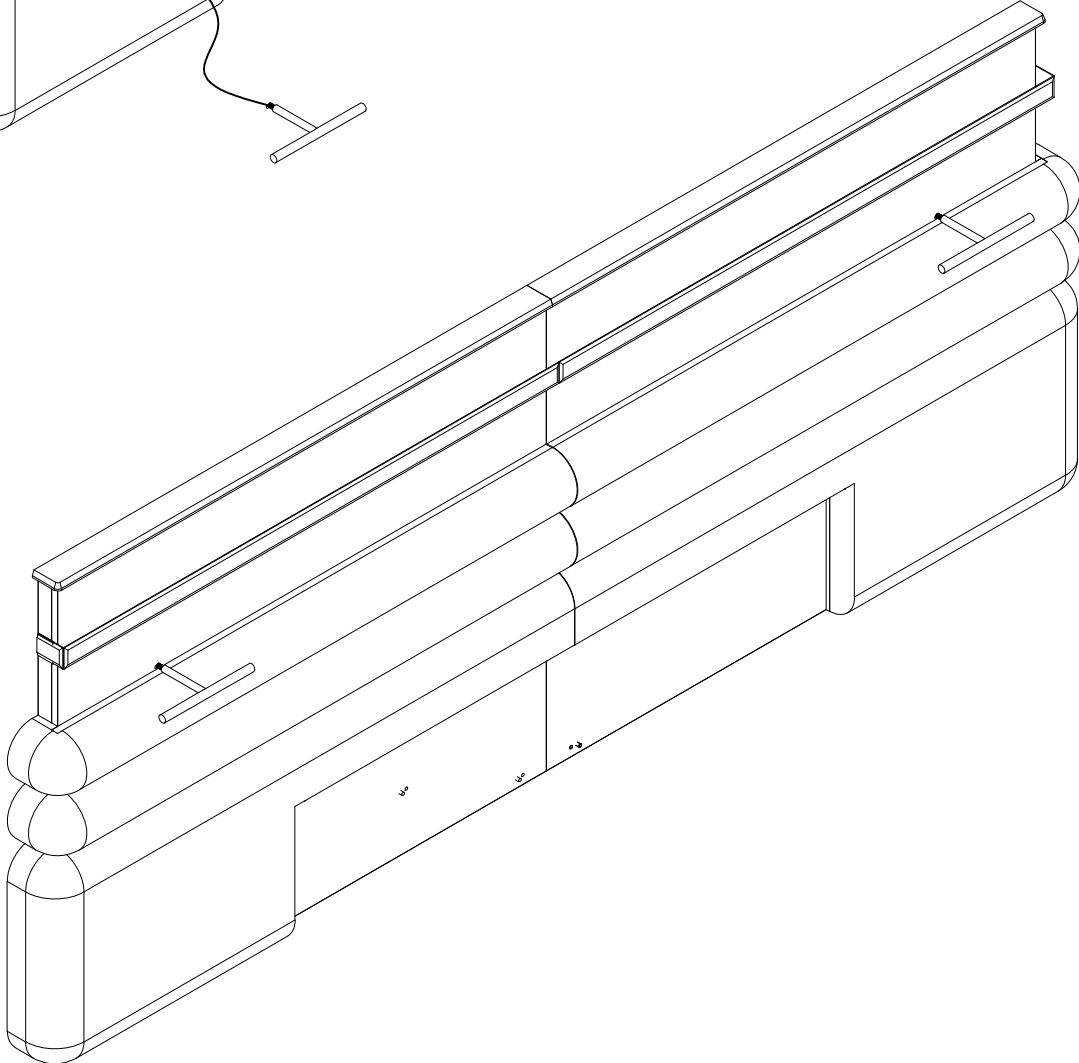
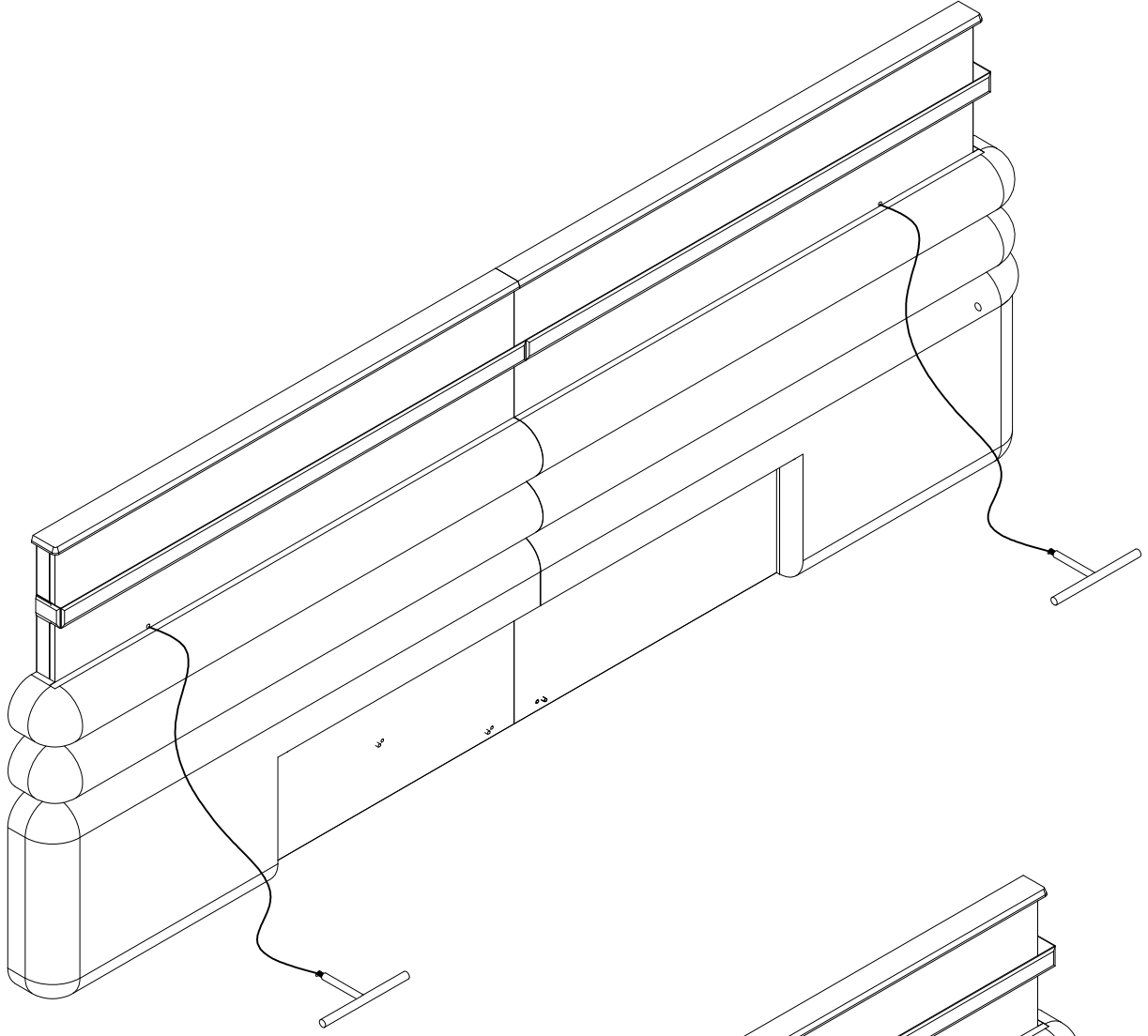

KERTIKLI DOSEMELER KERTIK YERLERI APLKERE GELECEK SEKILDE
BASTIRILARAK DOSEMELER PANOLARA 4*40 VIDA ILE SABITLENIR

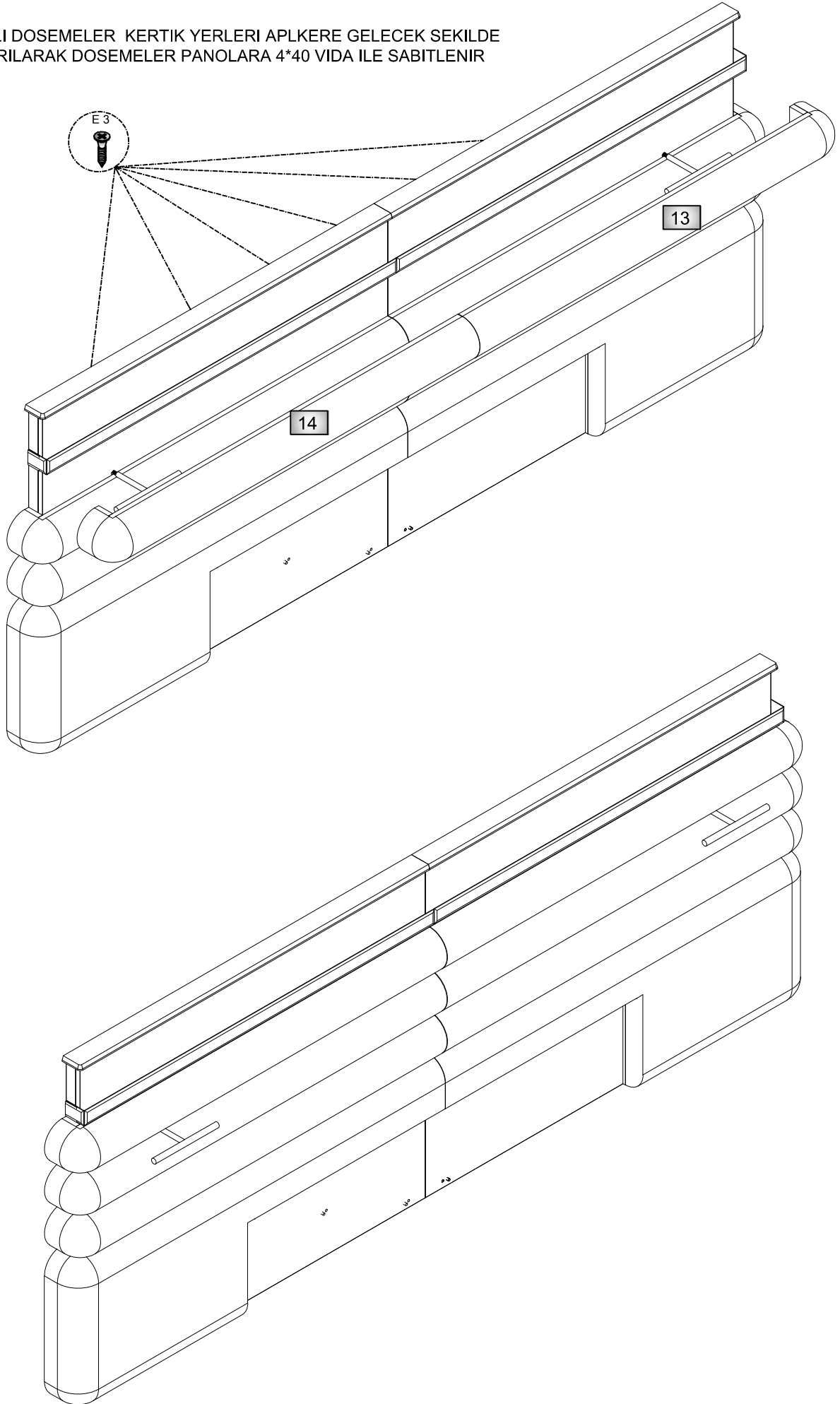

DOSEME ÜST PARÇAYA BASTIRILARAK DOSEMELER PANOLARA 4*40 VIDA İLE SABITLENİR

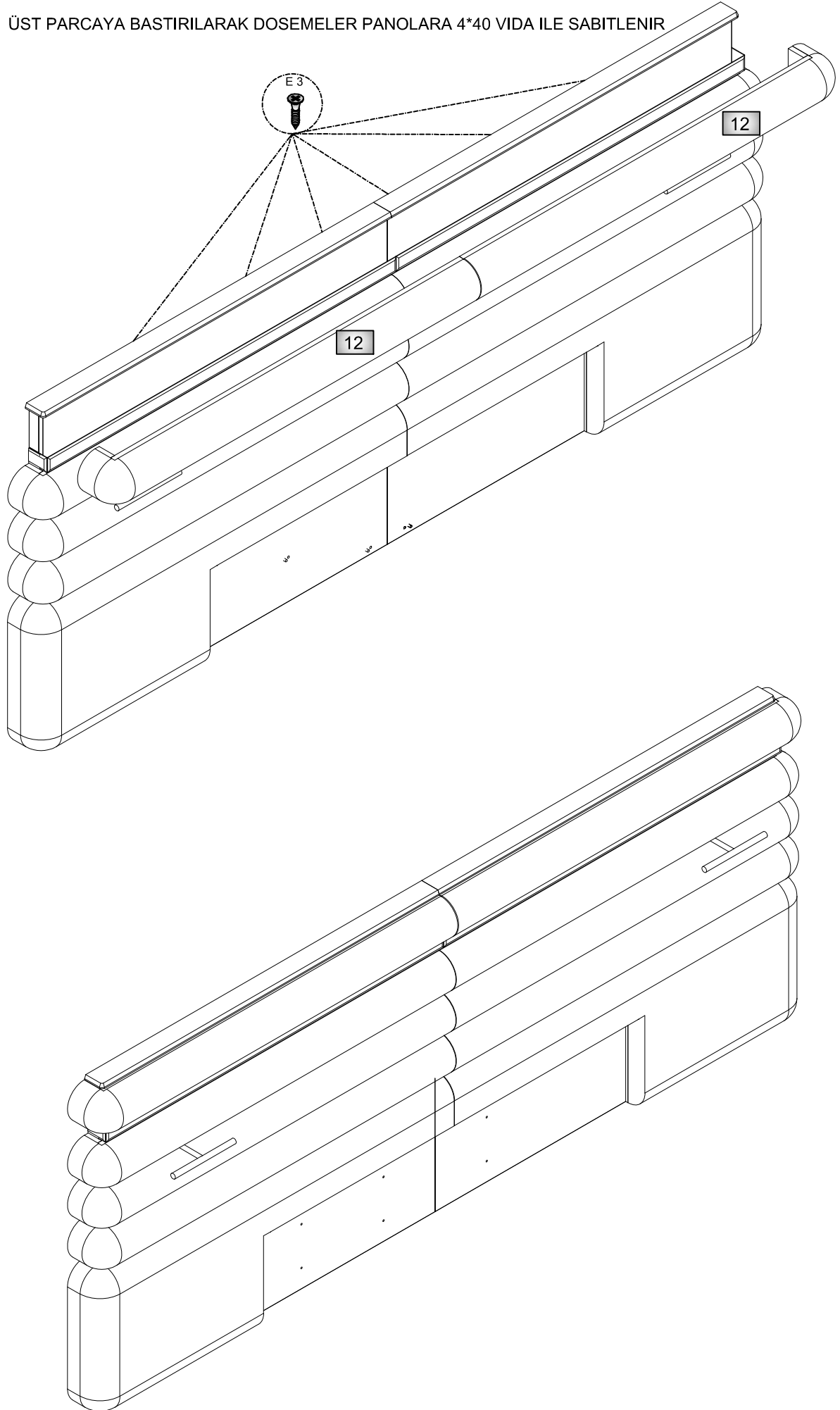

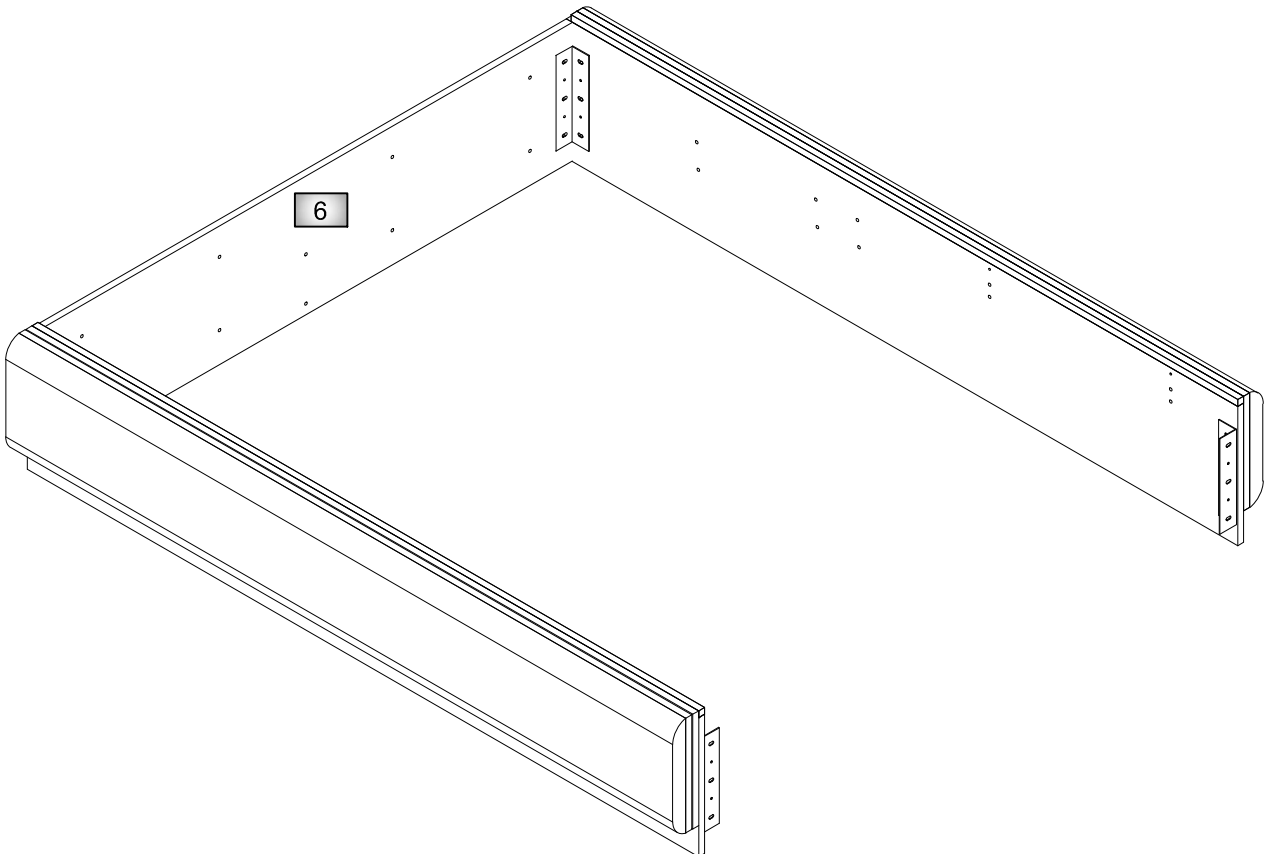
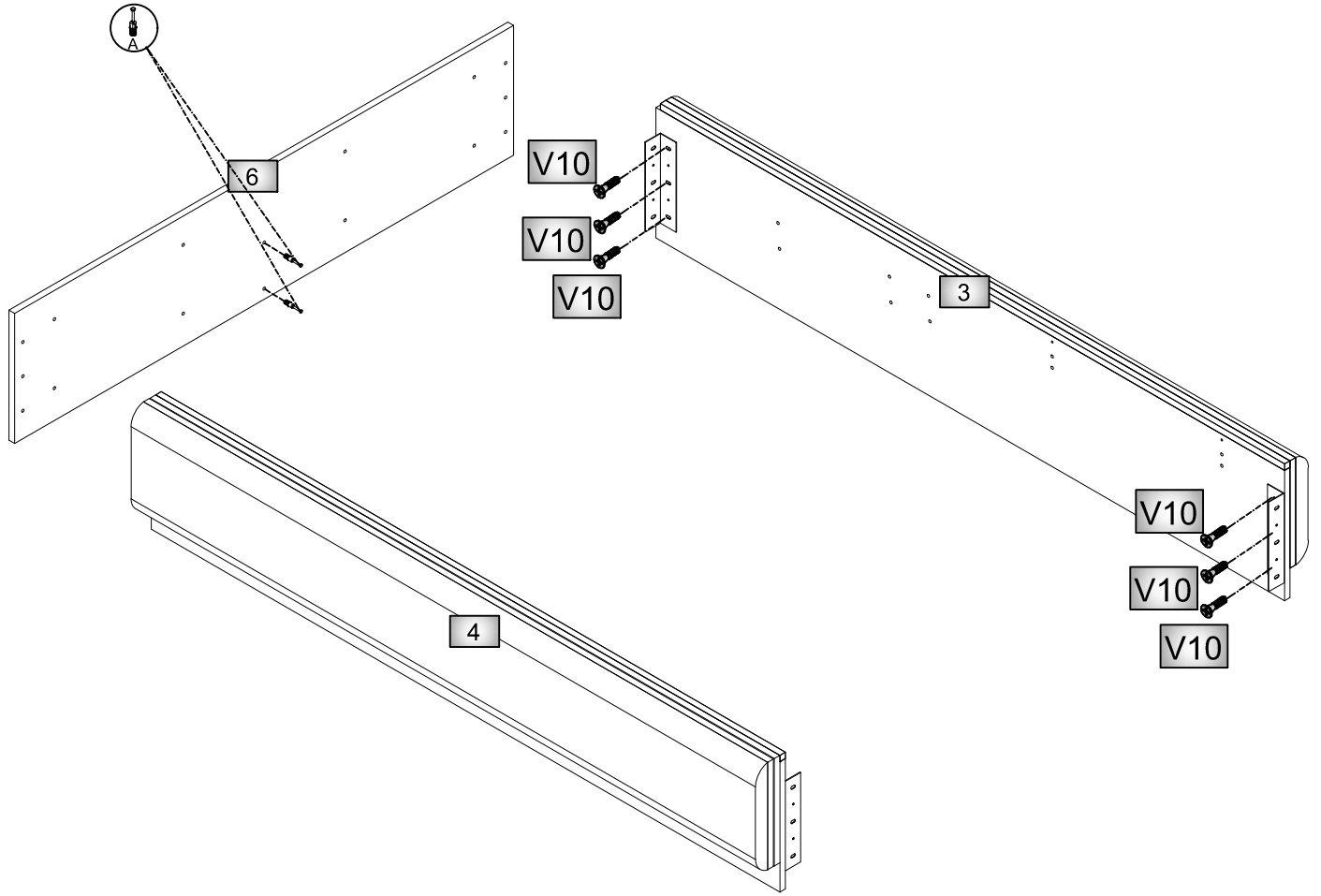

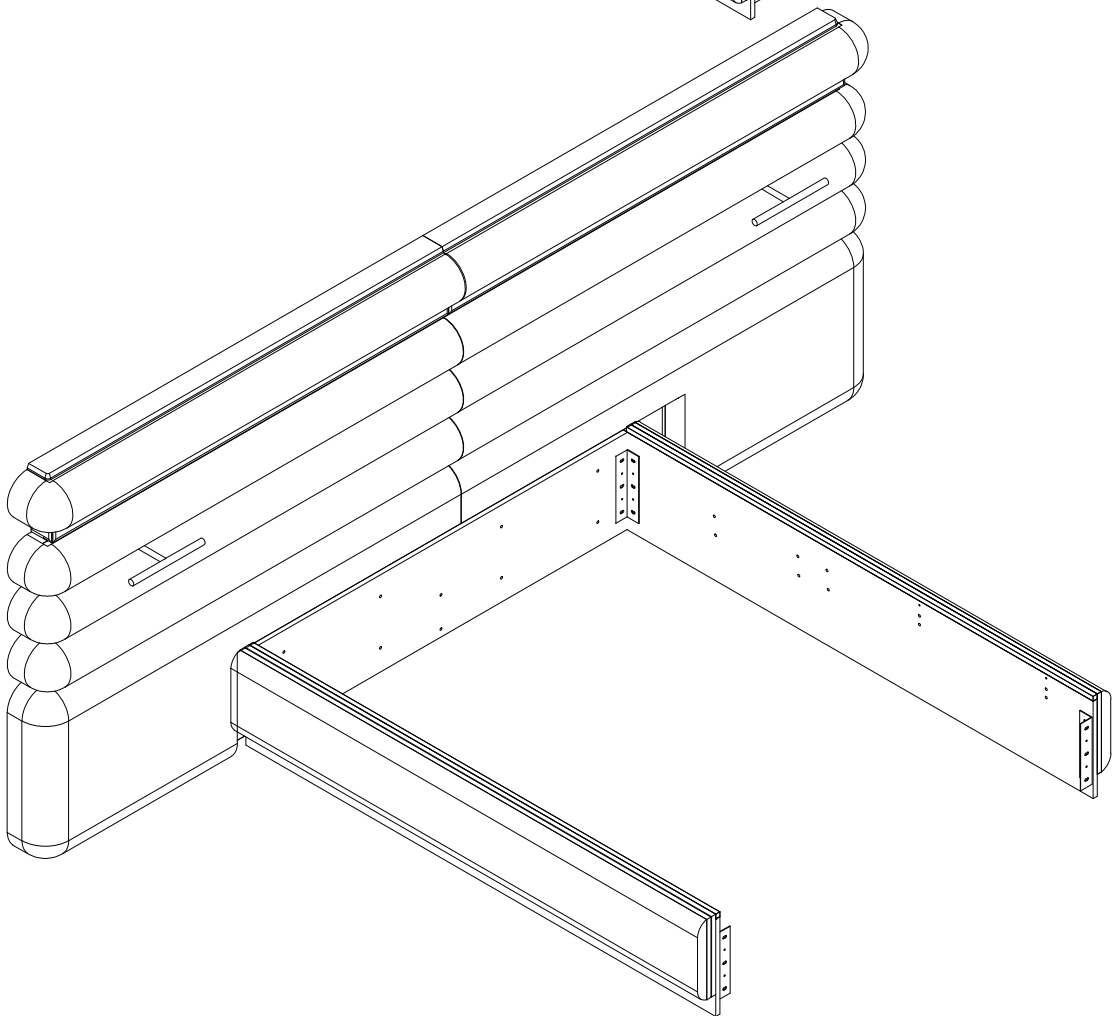
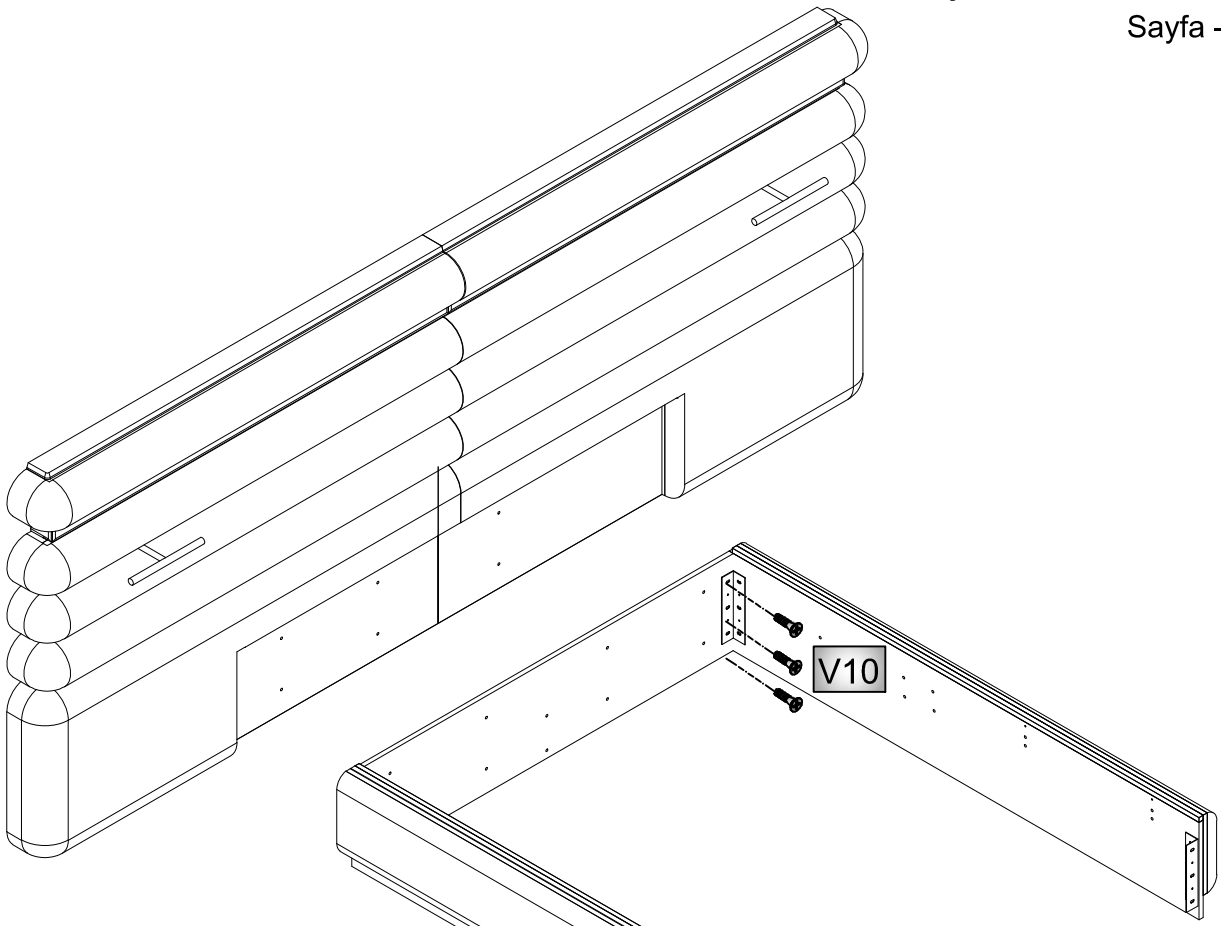

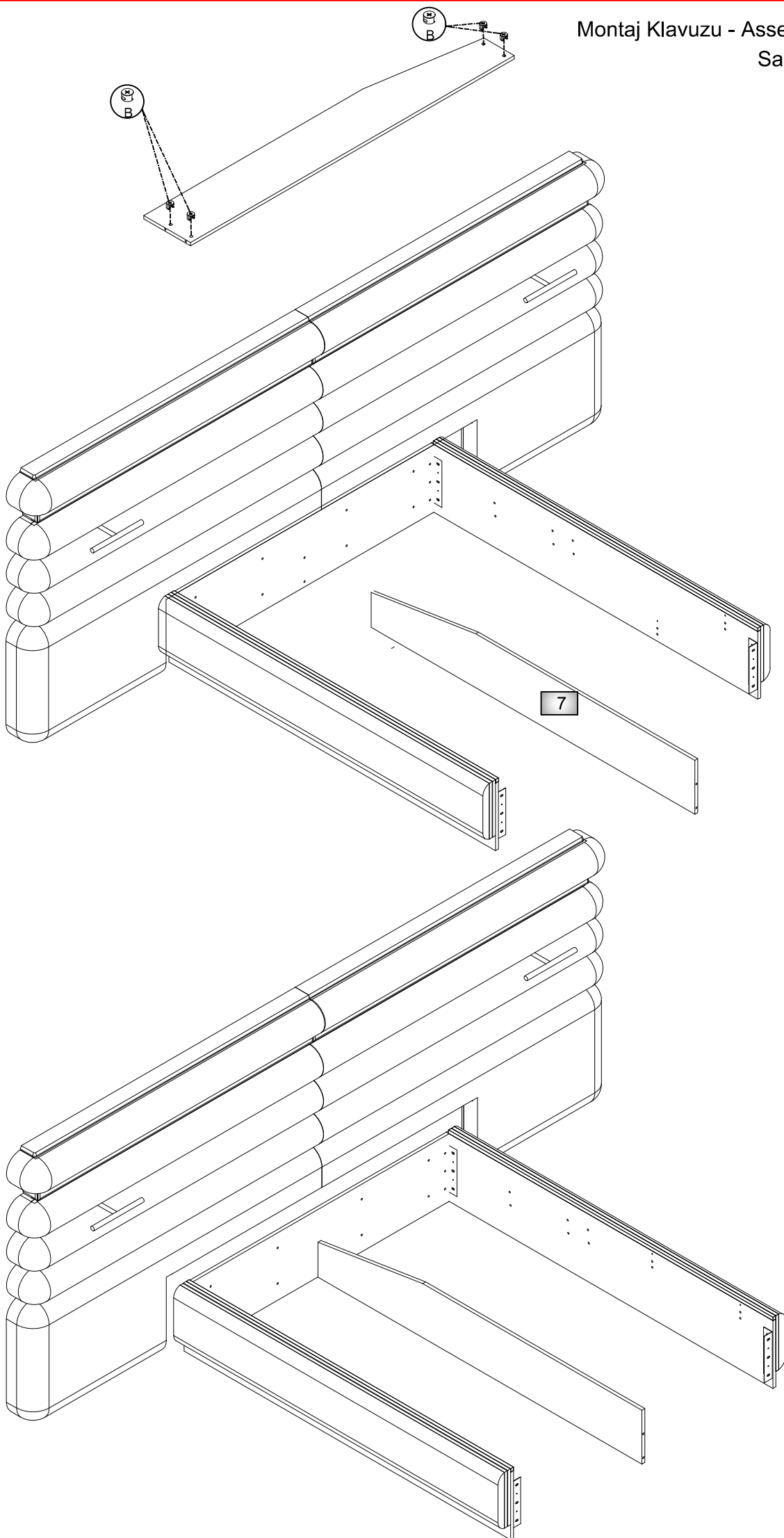

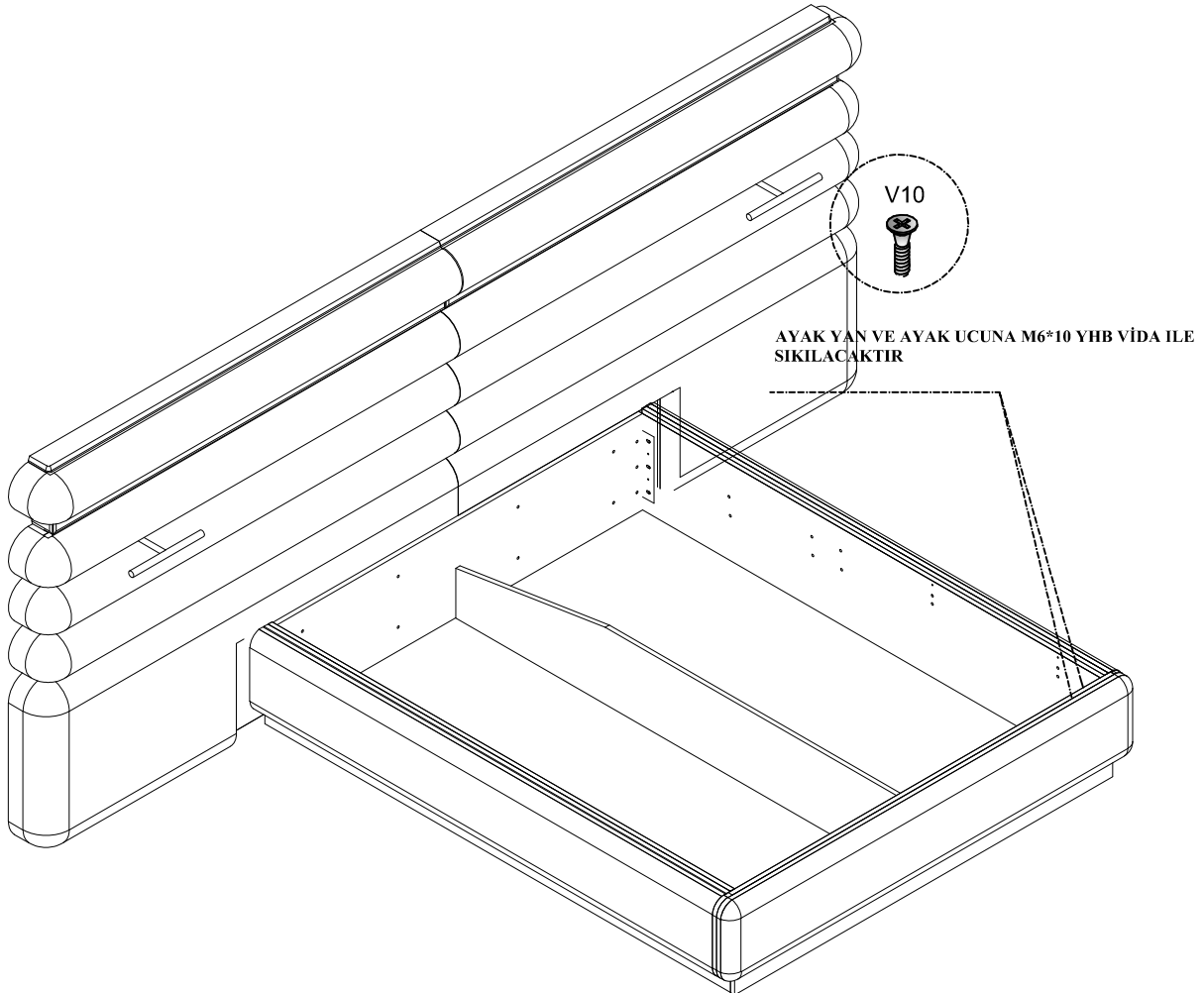
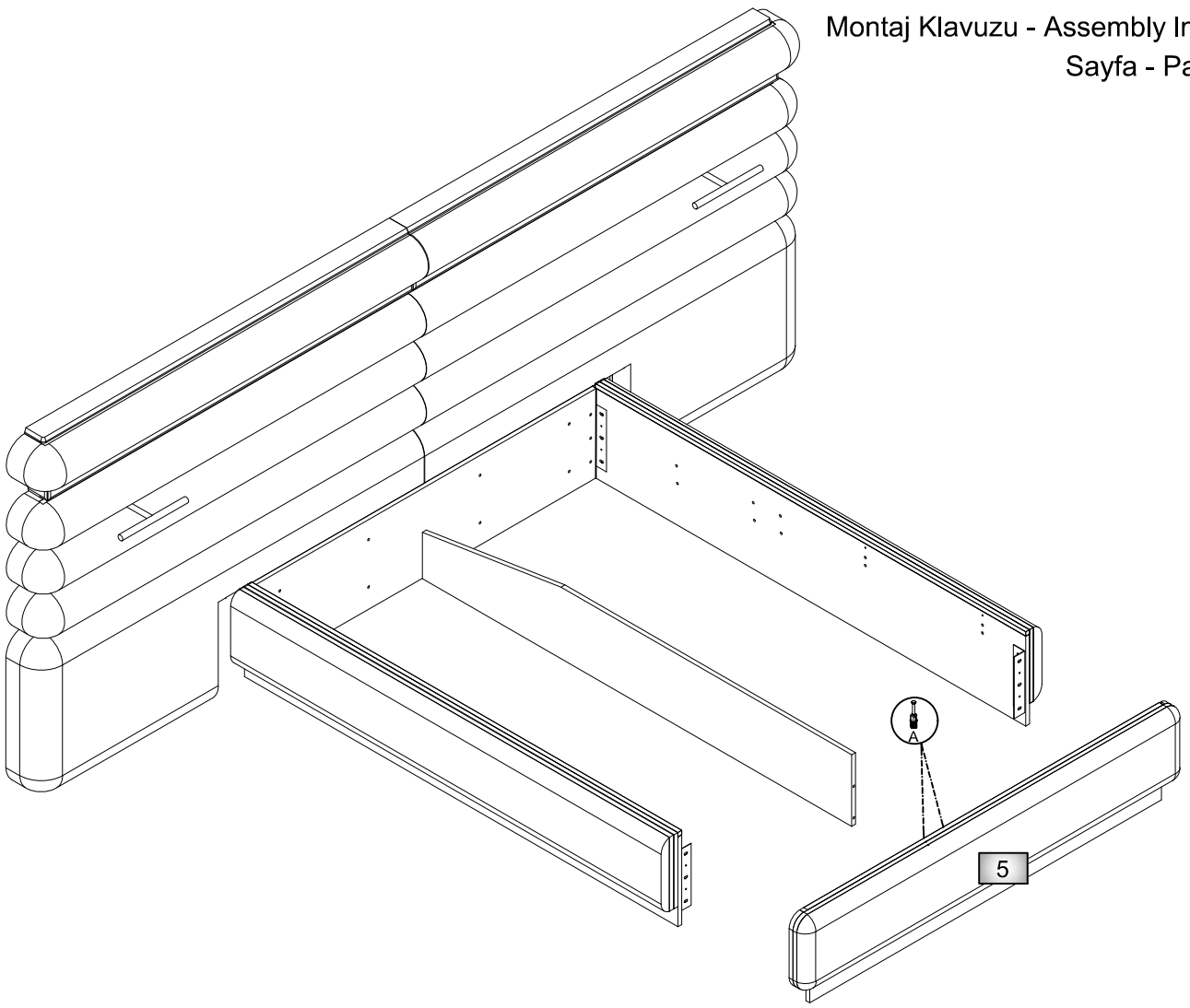

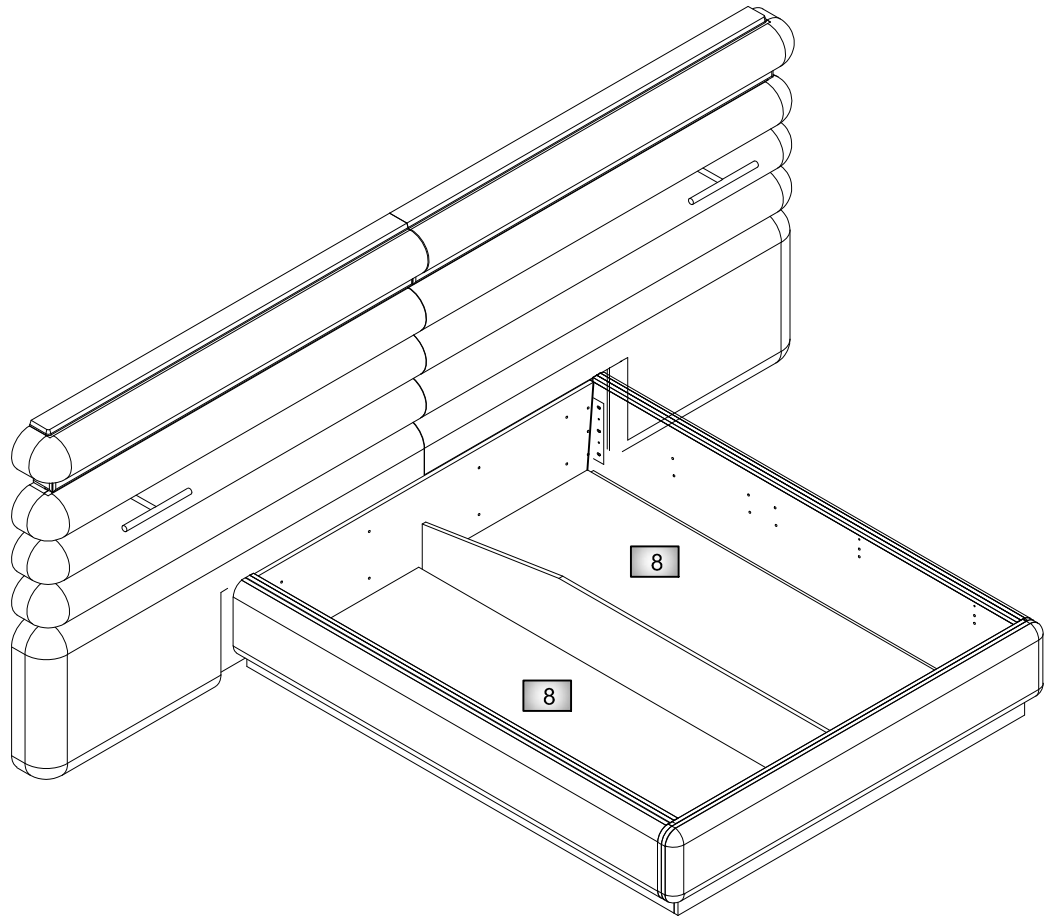
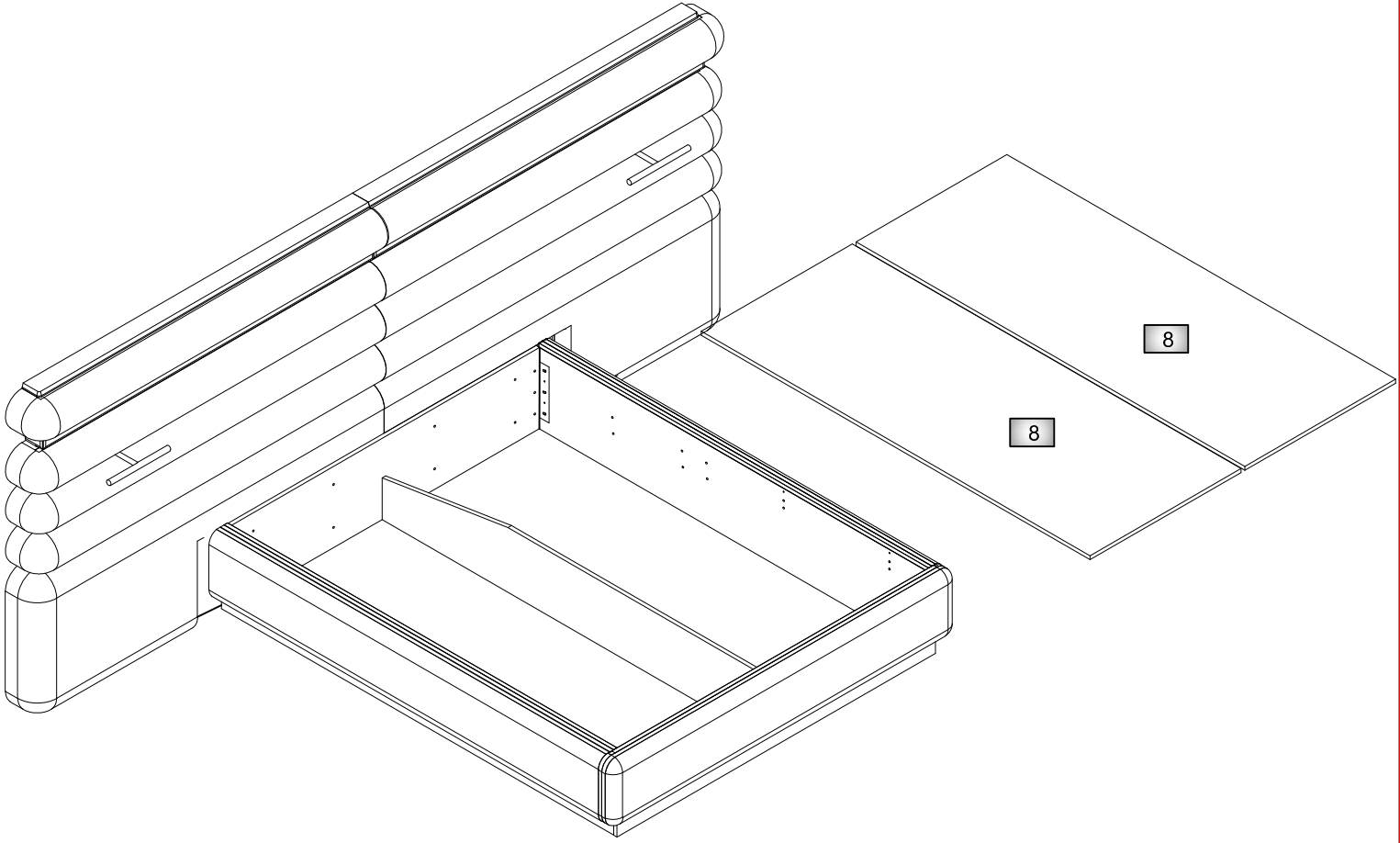

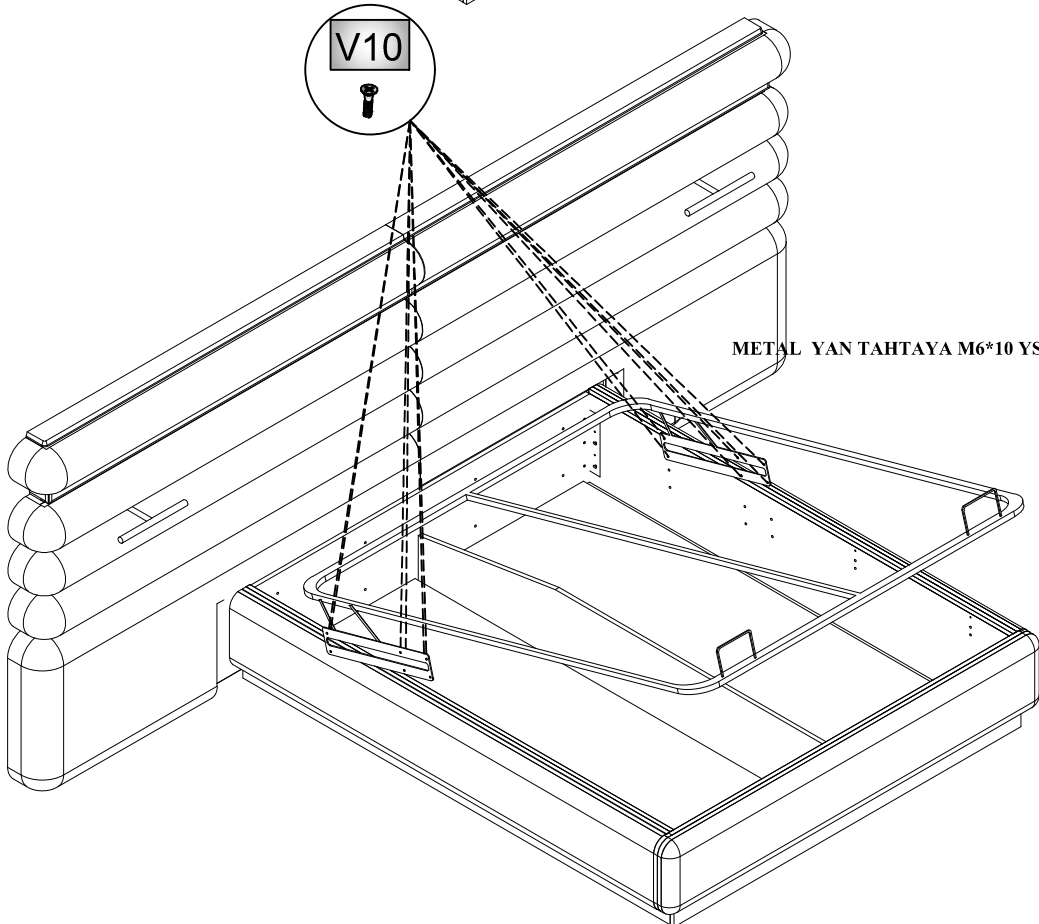
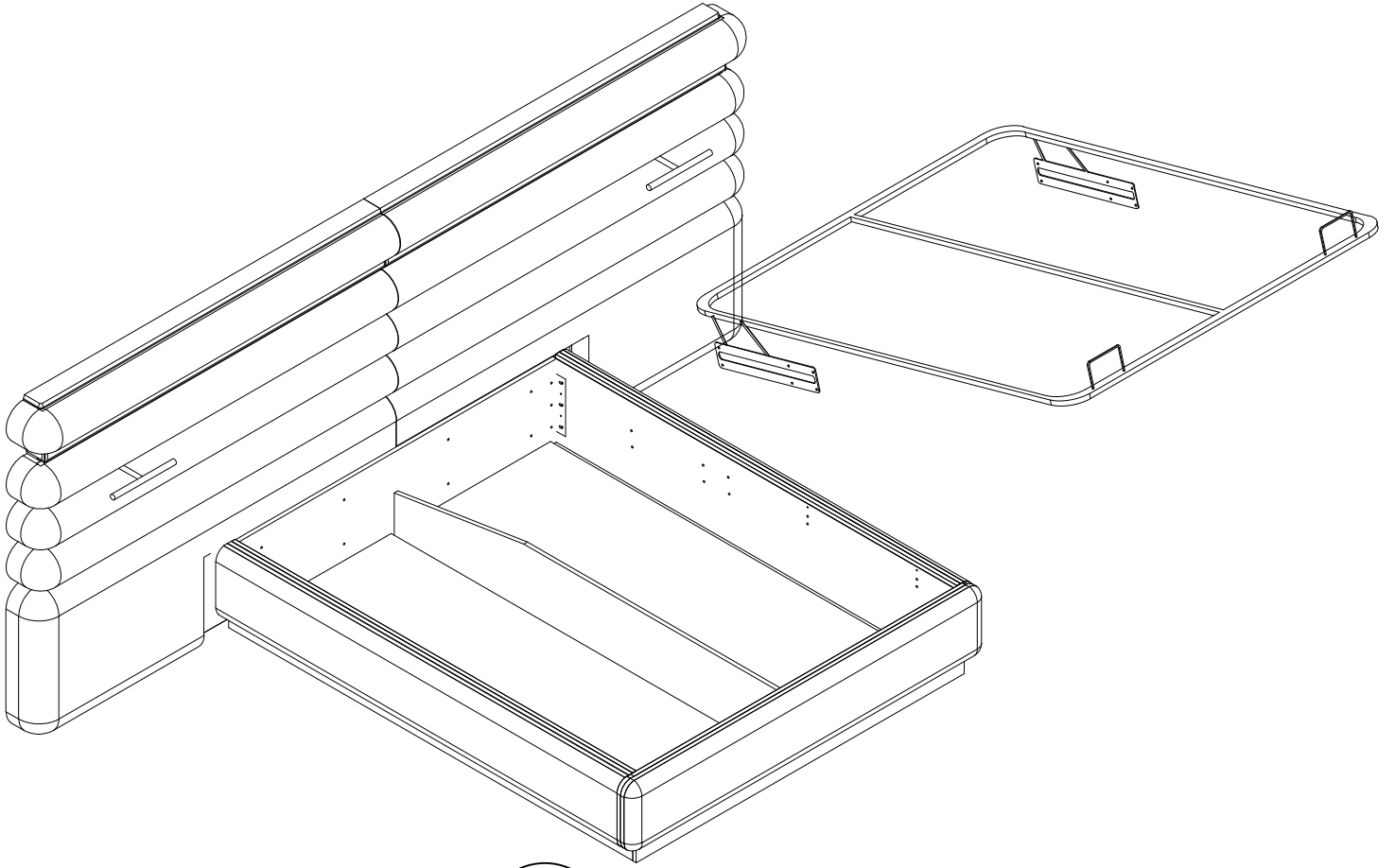

METAL YAN TAHTAYA M6*10 YSB İLE BAĞLANACAKTIR

METAL YAN MEKANIZMAYI YAN TAHTALARA SABITLEDIKTEN SONRA KAPAK SUNTALARI YERINE YERLESTIRINIZ

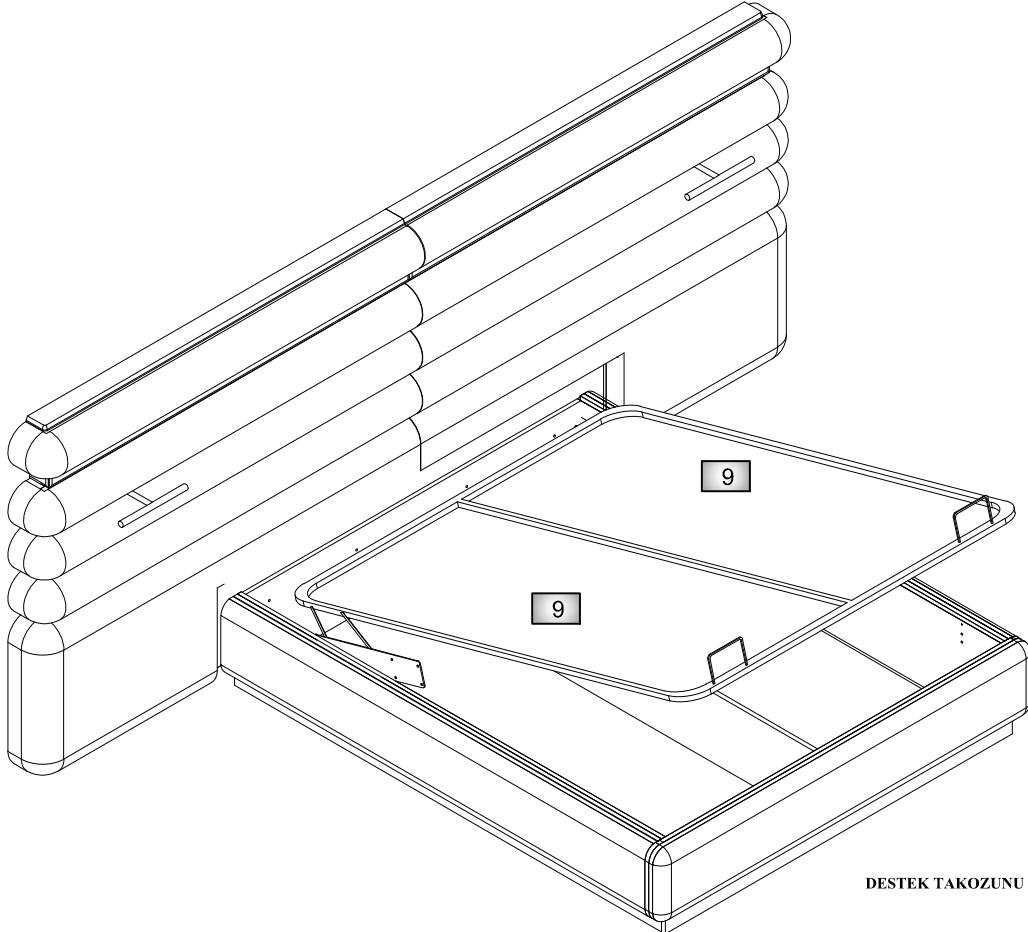
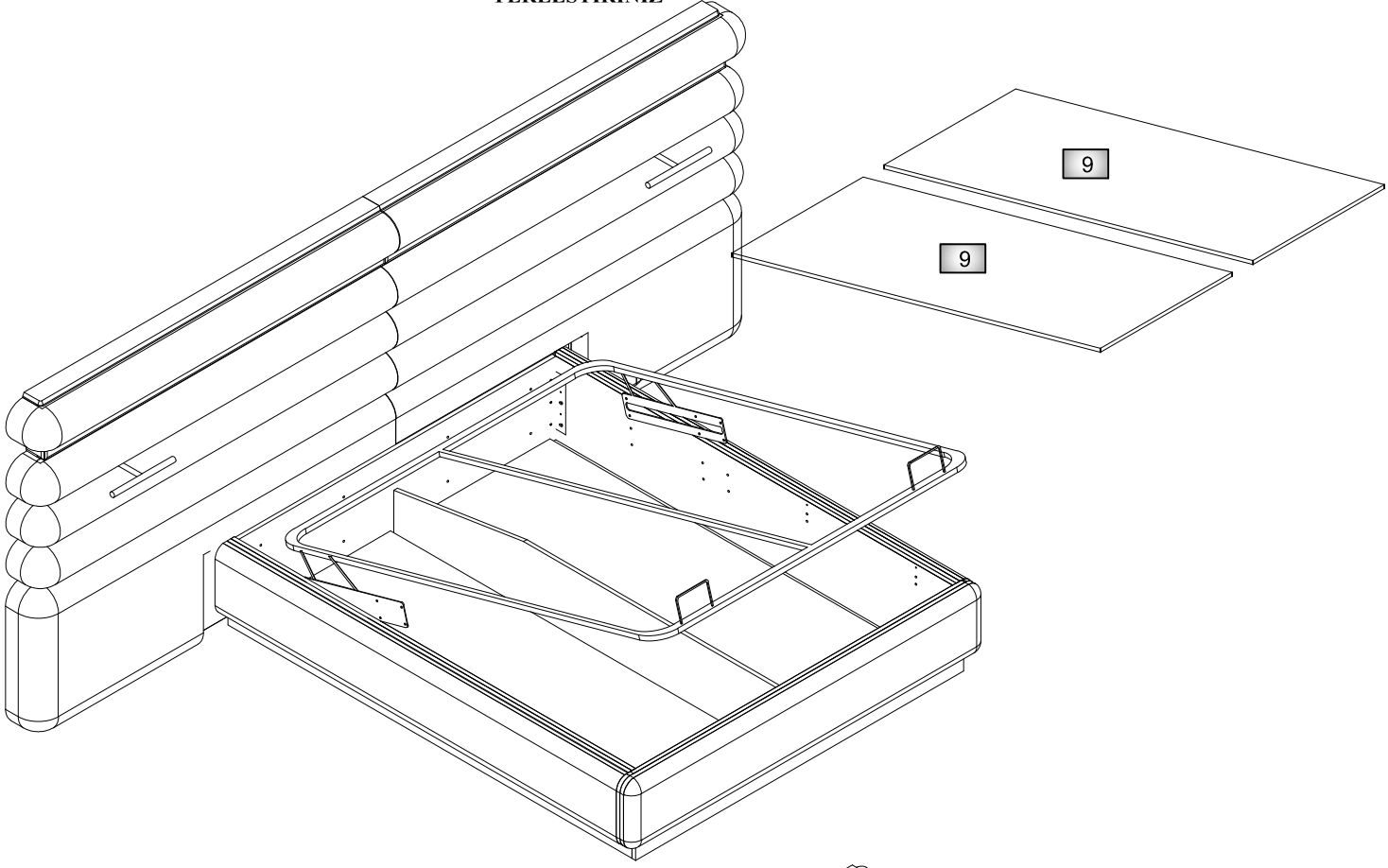

DESTEK TAKOZUNU SIKMAYI UNUTMAYIN